

KLOVENDRAIN PIPE PROPERTIES



KLOVEN DRAIN slotted drainage pipe provides an efficient and cost-effective solution for removing surface runoff in curb and gutter applications, or for intercepting sheet flow on relatively flat surfaces. Common applications include roadways, parking lots, airports, sports fields, or any surface where standing or flowing surface water needs to be removed.

KLOVEN DRAIN is made of corrugated steel that meets the applicable sections of AASHTO M36 and ASTM A760 standards.

The corrugated steel pipe is available with a wide range of protective coatings, each proven to perform in the most demanding environmental conditions. A service life of over 75 years can be achieved with the appropriate coating selected for the specific site and application. The pipe is manufactured using galvanized or aluminized steel to ensure long-term durability.

KLOVEN DRAIN is available in diameters ranging from 12 to 36 inches (30.48 to 91.44 cm) and in gauges 14 and 16.

The open slot of the KLOVEN DRAIN system is installed just below the surface to be drained. This allows surface water to flow directly into the lower pipe, where it can be routed to the appropriate stormwater collector. HULKO STEEL PIPE TECHNOLOGY 's slotted drain eliminates the need for complex surface grading or the creation of drainage basins that redirect water to multiple catch basins, curbs, dikes, or other drainage structures..

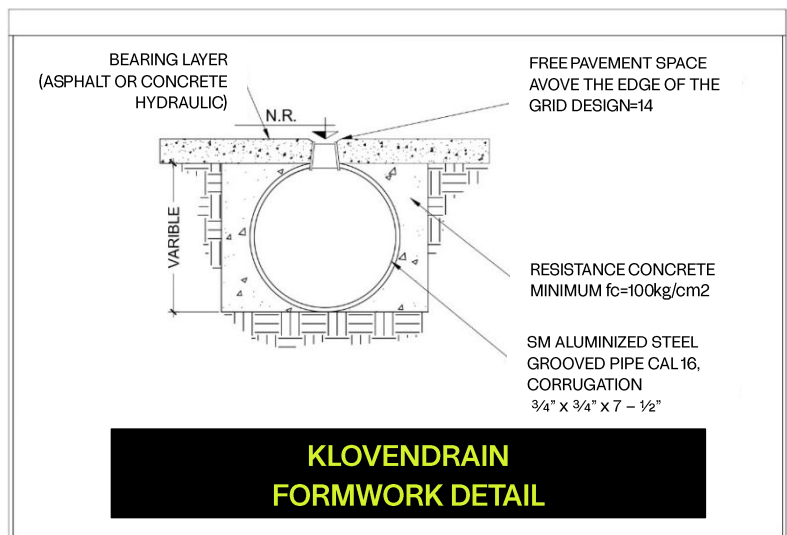

GRID DESIGN

For slotted drainage applications, specific structural requirements were identified in the design of the grate and its attachment to the pipe wall. The grate is made from 3/16" plate steel with spacers placed every 6 inches to maintain structural integrity. Standard grate height is either 2-1/2" (6.35 cm) or 6" (15.24 cm), with slot openings of 1-3/4" (4.45 cm).

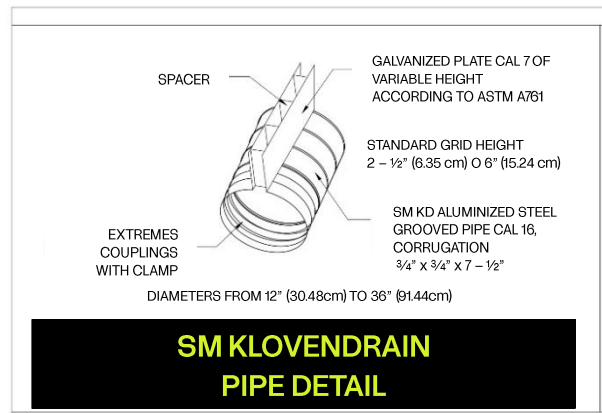
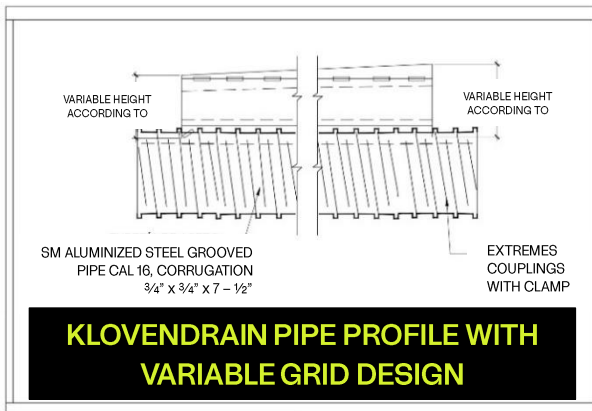
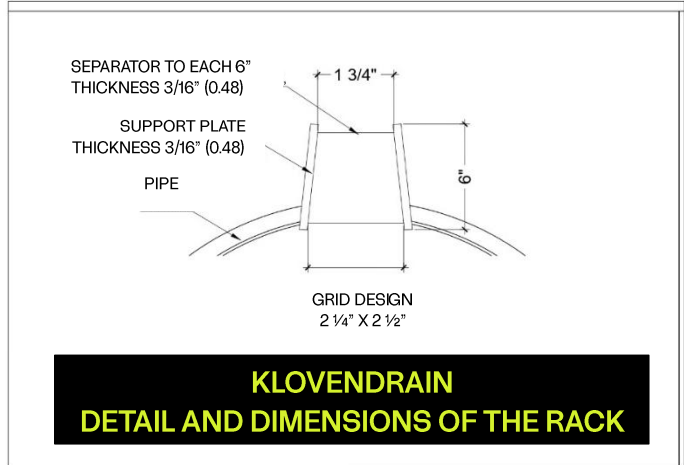

JOINTS AND COUPLINGS

KLOVENDRAIN slotted pipes come in standard 20-foot lengths and are typically joined using a metal coupling that matches the helical corrugation pattern of the pipe.

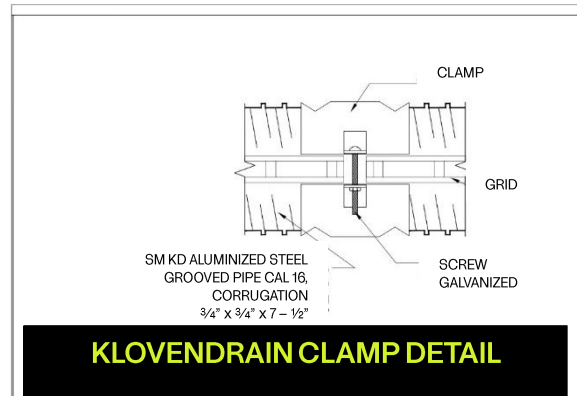

Type of Load	Filling Type	Pressure of Tires	Maximum Height of Grid
<H10	Granular		8"
H20 /H25	Concrete 1500 psi	125 psi	19"
Airport	Concrete 2000 psi	195 psi	12"

MESH FOR PEDESTRIAN USE & ACCESSORIES

When KLOVEN DRAIN is installed in pedestrian traffic areas, a galvanized mesh can be placed over the top openings of the drain to provide added safety and functionality.

If required by the project, custom components such as 90-degree tees, wyes, elbows at specified angles, as well as end caps, prefabricated access boxes, and other accessories can be manufactured. These accessories are supplied without grates.



Instalation Instruccions

1. The trench width should be pipe diameter + 6 inches.
2. Ensure the trench base is well-compacted (90% Proctor) and free of stones larger than 2 inches or organic materials such as roots.
3. Verify that the trench has the project-specified slope.
4. Place the first pipe section into the trench using the selected equipment, taking care not to damage the pipe.
5. Lay the remaining pipe sections, ensuring tight end-to-end contact, then install the clamp to secure the joint.



6. Shim the pipe so that it remains suspended 1 to 2 inches, ensuring the project slope is maintained.
7. Ensure the top of the grate sits approximately $\frac{1}{4}$ inch below the final surface level.
8. Cover the grate and upper part of the pipe with protective plastic sheeting to prevent debris from entering during installation and concrete pouring.
9. Once the pipe is properly aligned and supported, pour fluid concrete with a minimum compressive strength of 100 kg/cm^2 (F'c).
10. Pour the concrete in two stages:
 - First stage: Fill up to half the pipe's height, ensuring the pipe does not float.
 - Second stage: After the first pour has set, fill up to the crown of the pipe.
11. Apply the specified road surface material, ensuring the grate remains $\frac{1}{4}$ inch below the finished surface.
12. Remove any excess protective plastic from the grate.

